

1650 McReynolds Avenue, N.W.
Grand Rapids, Michigan 49504-2043
Phone: (616) 363-4416 Fax: (616) 363-0380
www.bulmanproducts.com

A681 PORTABLE RAZOR-X CUTTER
24", 36", 48", 60" INSTRUCTION SHEET

1. Attach the three hold down strips with two #10 x 1-3/4" round head bolts, two #10 lock washers, two #10-24 hex nuts and two #10 acorn nuts, as shown in the exploded assembly drawing.
2. Attach the two uprights to the base assembly as shown in the exploded assembly drawing.
3. Attach the cross bar, two roller dowel clips and the 3/4" diameter roller dowel to the uprights as shown in the exploded assembly drawing. NOTE: Attach the first roller dowel clip to the cross bar and upright, insert one end of the roller dowel into that clip. Insert the other end of the dowel into the unattached clip before securing it to the crossbar and upright.
4. Attach the dowel sockets to the uprights as shown in the exploded assembly drawing.
5. Attach the handle to one of the uprights as shown in the exploded assembly drawing.
6. Attach the four casters using four 1/2-13 hex nuts as shown in the exploded assembly drawing.
7. Insert the 1-1/4" feed dowel through the core of the material to be dispensed. If core plugs are included with your material, use them. Insert the dowel onto the dowel sockets.
8. Feed the material over the top of the roller dowel and under one, two, or all three of the hold-downs if necessary to prevent rollback.
9. Your A681 Portable Razor-X Cutter is ready to dispense.



A681 EXPLODED ASSEMBLY DRAWING

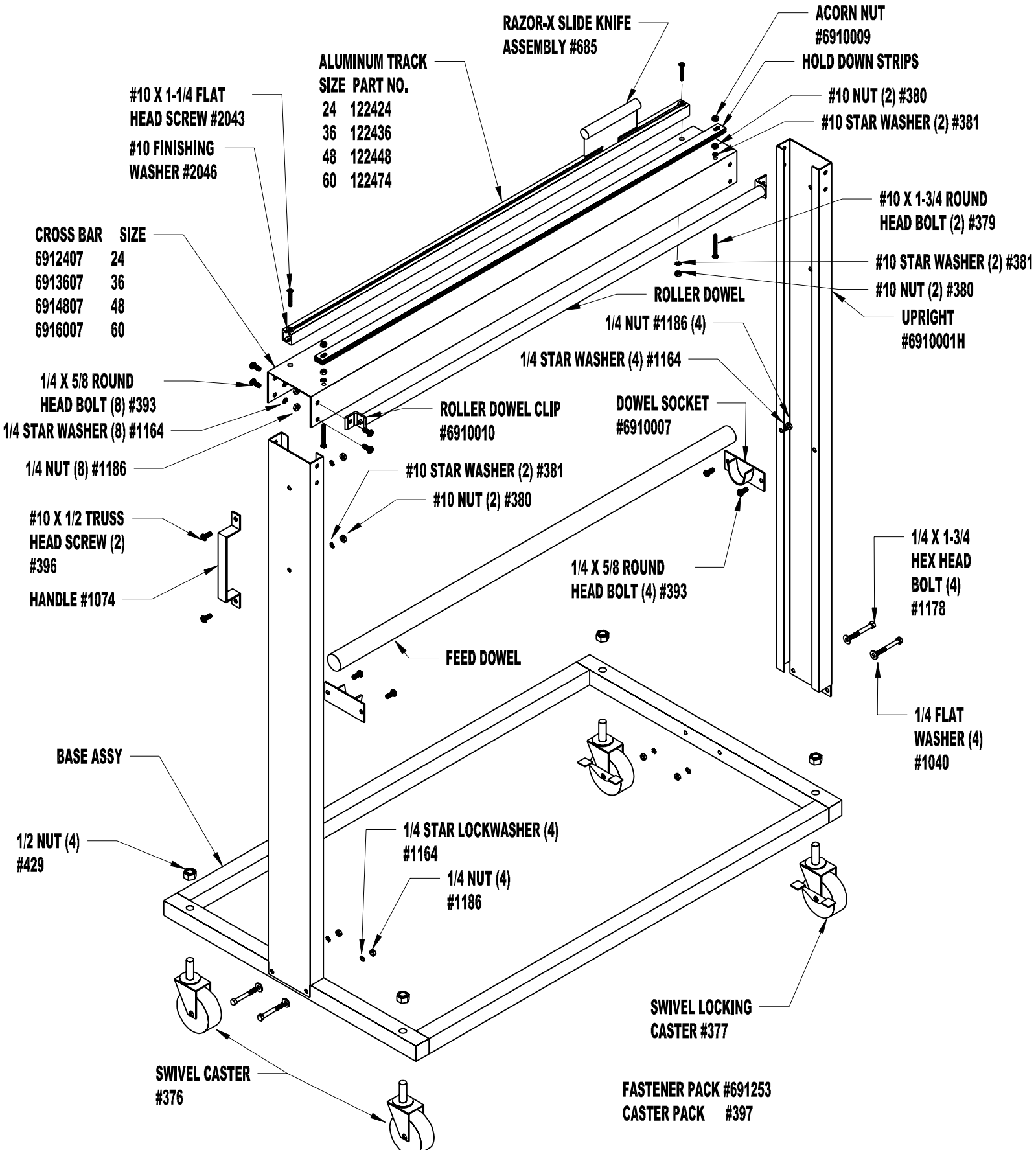

ROLLER HOLD SIZE	FEED DOWEL	DOWEL	BASE DWN STRIPS	ASSY
24	6912415	6912414	6912411	6912401
36	6913615	6913614	6913611	6913601
48	6914815	6914714	6914811	6914801
60	6916015	6916014	6916011	6916001

BULMAN PRODUCTS, INC. GRAND RAPIDS, MICHIGAN 49504-2043
 PHONE: 616-363-4416 FAX: 616-363-0380

C:\C71A691R\INS.PRT 5-12-2000
 LEVELS 14, 240

RAZOR-X SLIDE KNIFE ASSEMBLY

PART NUMBER 685

