



1650 McReynolds Avenue, N.W.
Grand Rapids, Michigan 49504-2043
Phone: 616-363-4416 Fax: 616-363-0380
www.bulmanproducts.com

R200 20 ROLL HORIZONTAL RACK ASSEMBLY INSTRUCTIONS

1. Make sure that you have all of the parts necessary to assemble the R200 20 roll rack as shown on parts list.
2. Attach the two 24" long feet to the four uprights using eight each of the following: ¼- 20 x 2" hex head bolts, ¼" flat washers, and ¼-20 keps hex nuts as shown in Figure 1.
3. Attach the two bottom cross tube supports to the two pairs of uprights using four of each of the following: ¼-20 x 2" hex head bolts, ¼" flat washers and ¼-20 keps hex nuts as shown in Figure 1.
4. Slip each R200 cutting device over the two uprights as shown in Figure 1. One R200 cutting device will be placed on each side of the rack.
5. Attach the top cross tube support to the two pairs of uprights using four each of the following: ¼-20 x 2" hex head bolts, ¼" flat washers and ¼-20 keps hex nuts as shown in Figure 1.
6. Attach casters as shown in Figure 1.
7. Now the rack is ready to be loaded.
8. The standard R200 cutting device is designed to be adjusted up or down to the specific roll being dispensed, or it can be mounted at a comfortable operating height, and paper can be brought up or down to the device by using the roll of paper closest to the cutting device as a feed roller. NOTE: It might be necessary to position a rubber band around the "feed" paper roll so the paper does not unroll while it is turning.

1650 McReynolds Avenue, N.W.
 Grand Rapids, Michigan 49504-2043
 Phone: 616-363-4416 Fax: 616-363-0380
 www.bulmanproducts.com

R200 20 ROLL HORIZONTAL RACK PARTS LIST & OPTIONAL EQUIPMENT

<u>PART NUMBER</u>	<u>QUANTITY</u>	<u>DESCRIPTION</u>
20021	4	Uprights with 10 dowel sockets
20022	2	Feet
65548	20	Metal dowels 1/2" x 49 3/4"
67070	20	1/4-20 x 2" hex head bolts
11860	20	1/4-20 keps nuts
1040	20	1/4 flat washers
20006	2	Bottom cross tube support
20004	1	Top cross tube support
20009	2	M200 cutting device assembly
M885	2	Cutter
397	1 set	2 swivel, 2 locking casters

Optional Equipment

M800-48	1	M800-48 Measuring Device
20048	20	3/4" x 49 3/4" Metal dowel
800008	40	1 7/8" OD x 13/16 ID washers



BULMAN Products, Inc.

1650 McReynolds Avenue, N.W.
Grand Rapids, Michigan 49504-2043
Phone: 616-363-4416 Fax: 616-363-0380
www.bulmanproducts.com

R200 20 ROLL DISPENSER

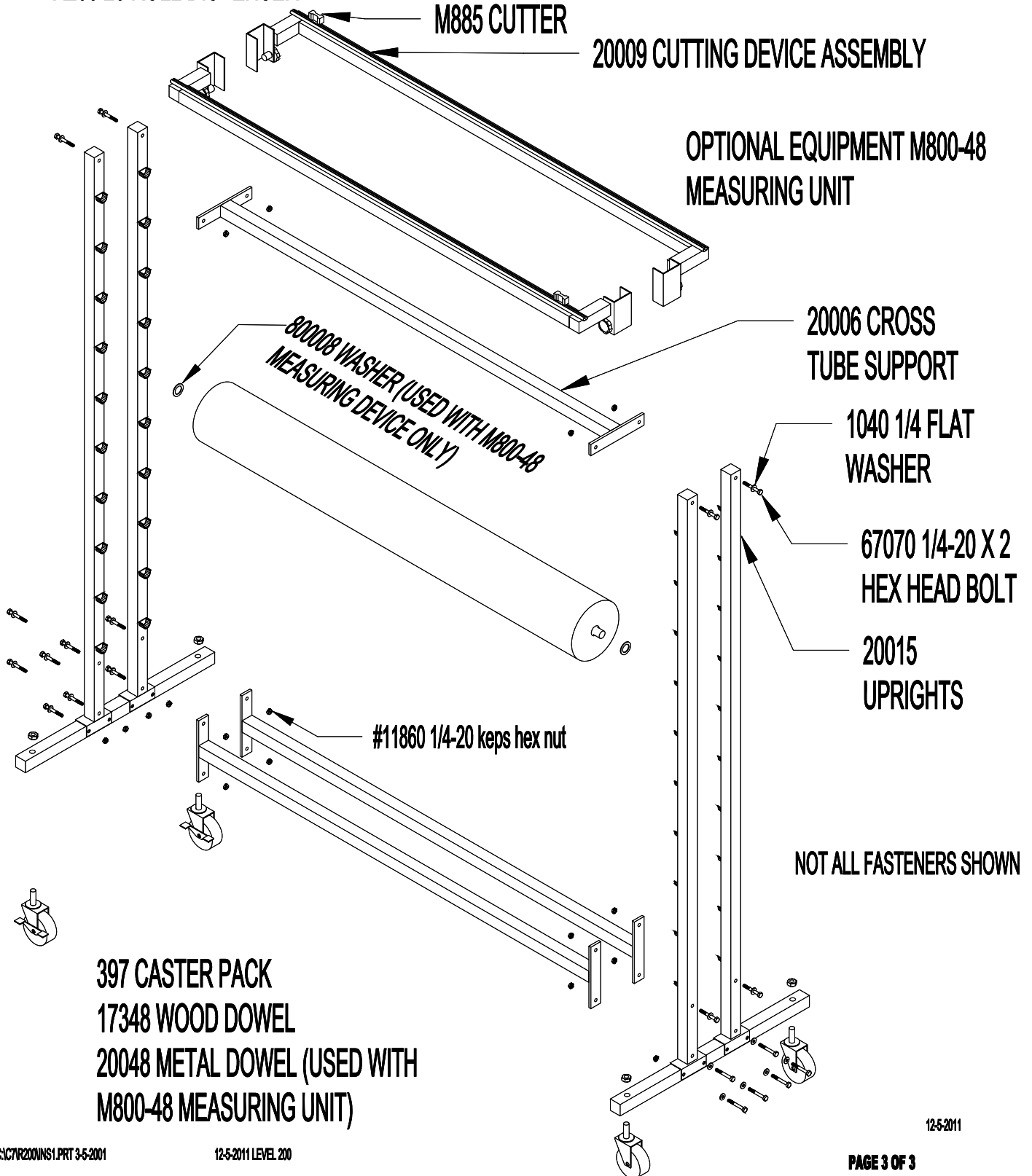

12-5-2011