

# ▼▼▼▼▼ BULMAN Products, Inc.

1650 McReynolds, N.W.  
 Grand Rapids, Michigan 49504-2091  
 616/363-4416, 616/363-4417  
 Fax: 616/363-0380

## R995 K.D. 8 ROLL VERTICAL RACK ASSEMBLY INSTRUCTIONS

**\*\*TOOLS NEEDED: ADJUSTABLE WRENCH, PLIERS AND/OR SOCKET WRENCHES**

1. The unit is shipped complete in one carton containing four cutter C-sections, eight metal dowels, casters and all hardware. Each C-section comes equipped with blades, arms and spring tension assemblies already installed.
2. To begin assembly, place two C-sections with large dowel holes facing upwards as shown (Figure 2). Fasten with two 1/4-20 x 1-3/4" bolts, nuts and washers. Finger tighten only.
3. Repeat Step 2 with the other two C-sections to form a square. Then tighten securely after all the sections are in place.
4. Install the casters at the base of the unit as shown, tighten securely.
5. Next, assemble the eight lower paper assemblies as shown in Figure 1. Install at the base of the unit; face the flat side of the large washer toward the cutting blade. Tighten all securely.
6. The eight metal dowels are provided to secure the paper roll at the top of the C-section. To load paper, pull the blade out of its closed position until it locks open. Lift the paper roll onto the lower paper assembly. Continuing to hold the paper in place, insert the metal dowel into the large hole at the top of the frame and push into the core of the paper roll. When installing your roll of material, be sure to position the paper roll properly so paper can be torn against the blade.

### ASSEMBLY HARDWARE

8	-	1/4-20 x 1-3/4" bolts
8	-	1/4" flat washers
8	-	1/4" star washers
8	-	1/4-20 hex nuts
8	-	5/16-18 x 4" bolts
8	-	5/16" lock washers
8	-	small spacers
8	-	3-1/4" diameter washers
16	-	5/16" sae washers
8	-	large washers
8	-	5/16-18 hex nuts
4	-	1/2" hex nuts (for casters)
2	-	locking swivel casters
2	-	swivel casters
8	-	metal dowels

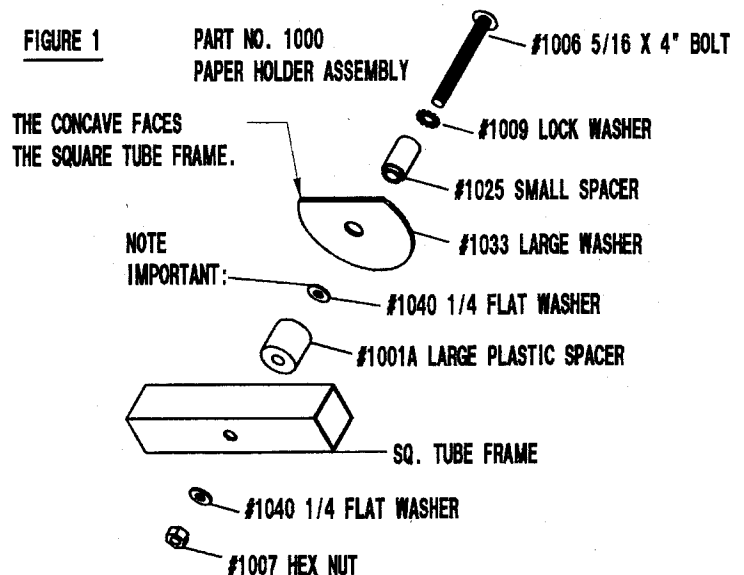

R995 K.D. 8 ROLL  
VERTICAL RACK  
PATENT PENDING

FIGURE 2

