

Trim Master Cutter

ASSEMBLY INSTRUCTIONS

BULMAN PRODUCTC, INC. 1650 McReynolds Ave., NW, Grand Rapids, MI 49504

616/363-4416, Fax: 616/363-0380

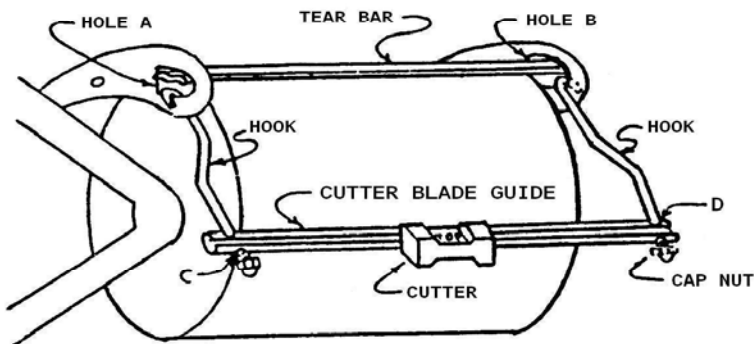

WALL MOUNT

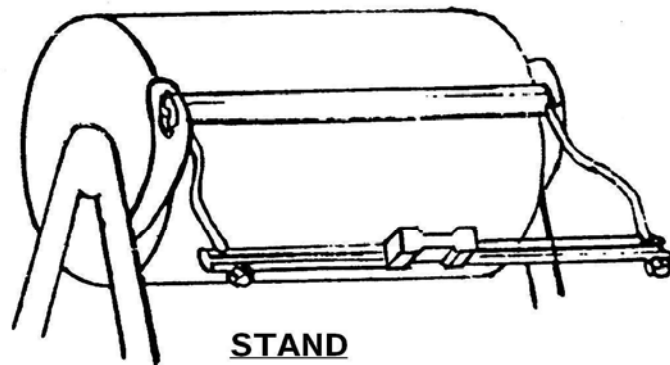

STAND

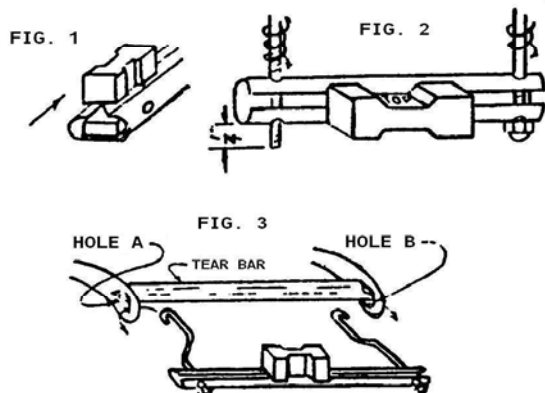

1. INSERT CUTTER INTO SECTION BLADE GUIDE. Important: The cutter is designed to fit in cutter blade guide only one way. It should slide freely the length of the guide without binding. If cutter binds, please remove and turn over before reinserting.

2. POSITIONING CUTTER AND BLADE GUIDE. Now the blade guide with the cutter inserted properly must be positioned so that the word "TOP" on the cutter is facing up. Figure 2.

3. INSERTING WIRE HOOKS. The hooks are designed to be screwed down through the holes in the ends of the cutter blade guide. (Some pressure may be needed initially as the hangers cut their own threads.) Threads should extend approximately 1/4" below blade guide. Figure 2.

4. ATTACHING ASSEMBLY TO ROLL HOLDER. Position wire hooks as shown in Figure 3. First snap into Hole A and then Hole B. Some adjustment from right to left or left to right will be necessary to snap into holes.

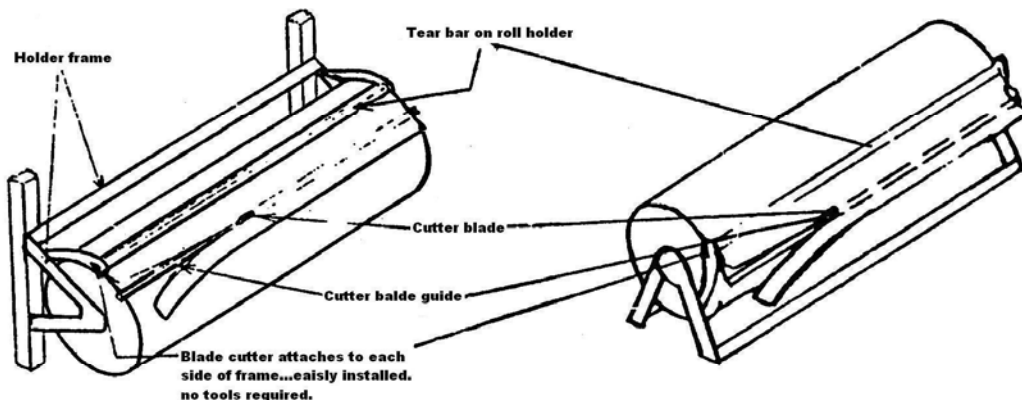

TO OPERATE:

Slide the cutter to one end of the channel. Run the paper under the tear bar and over the cutter blade channel. Pull the paper out to the desired length. Grasp the vertical edge of the paper near the cutter slightly below the channel. Pull the edge of the paper taut over the channel where the cut is to be started. Use the other hand to draw the cutter across the paper. The cutter cuts from either side.

